

SD-180 Dough Divider



SD-180 is a noiseless automatic suction-feed dough divider for all types of dough. Robust construction and high weight accuracy, combined with a high degree of flexibility regarding weight range and types of dough makes the SD-180 well adapted to all types of bakeries.



Sveba Dahlen Group



Scandinavian know-how – worldwide

SD-180 Dough Divider

Variable speed with frequency converter as standard



Easy-to-remove covers facilitate the daily cleaning

Transfer roller (option) for sticky dough



26.4 US gal, 154 lb dough hopper



Dough knife in stainless steel direct connected to the hopper provides an optimal emptying of the hopper

Oilreservoir 4.5 US gal, easy to fill

Accessories

Elevating conveyor with two parallel conveyor belts	Conveyor for feeding directly into moulder unit
Flour duster, electrical	Flour duster on the outfeed conveyor, electrical
Flour duster, mechanical	Flour duster on the outfeed conveyor, mechanical
Frequency converter with display	Display with speed in pcs/h, piece counting and pre-set counting
Hander-up	Small rounding unit for lines without conical rounder
Hopper 59.5 US gal	Dough Hopper 59.5 US gal = approximately 330 lb dough, delivered on new SD from factory
Hopper lubrication for 59,5 US gal hopper	Automatic lubrication inside the dough hopper, by means of a spread tube system
Mini Piston	Adapter for dough weight 1.2 oz - 9 oz, available for SD180 and SD180XL
Non-stick coating of hopper 26.4 US gal	Interior of the dough hopper 26.4 US gal non-stick to assure a smooth infeed of the dough
Non-stick coating of hopper 59.5 US gal	Interior of the dough hopper 59.5 US gal non-stick to assure a smooth infeed of the dough
Oiling of belt	Oiling device for oiling on the outfeed conveyor
Piece counter	Mechanical piece counter
Speed reduction kit	Low-speed kit for reduction of speed to 520-1200 pcs/h instead of 750-1800 pcs/h
Special length on outfeed conveyor 7 7/8" - 31 1/2"	Outfeed length from divider frame, 3 3/32" interval (Standard is 14 1/64")
31 1/2" - maximum 59"	Outfeed length from divider frame, with adjustable support, 3 3/32" interval
Special belt	Special customized belt
Transfer roller	Support driven roller at the end of the outfeed conveyor, for sticky dough

Technical data

Capacity range	750-1800 dough pieces/hour
Weight range SD-180	4.3 oz-3.5 lbs
Weight range SD-180XS	2.5 oz-2.2 lbs
Weight range SD-180XL	6.3 oz-5.0 lbs
Power Supply	1.1 kW
Weight, net	1190 lbs
Weight, gross (carton+pallet)	1466 lbs
Volume, gross	5.6 x 2.9 x 6.7 = 109 ft ³
dB(A)	72

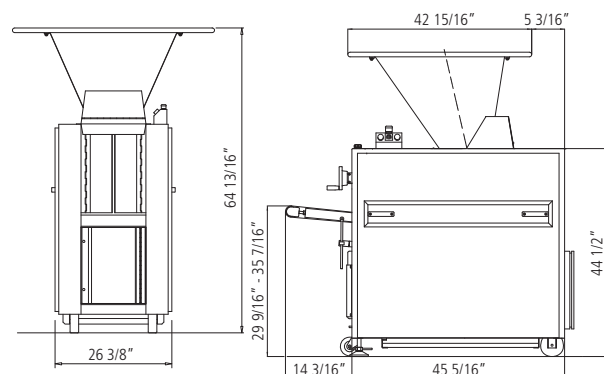

Glimek AB
 Box 124
 S-280 64 GLIMÄKRA
 Sweden
 Tel. int. +46-(0)44 449 00 • Fax +46-(0)44 449 10
 e-mail: office@glimek.se • www.glimek.se



Belshaw Adamatic Bakery Group
 814 44th St NW
 Suite 103
 Auburn Washington 98001
 USA
 Phone: +1 732 544 8400
 Fax: +1 732 544 0735